

Balcrank®

HAND OPERATED OIL AND ATF PUMPS

Models: 1300-010 1300-017*
1300-011 1300-018*
***with dolly**

Examine All Parts

Carefully unpack all parts and examine thoroughly for any damage that may have occurred during shipment.

Report to your trucker or carrier immediately any damage or missing parts before putting unit into operation.

To Assemble Pump

- 1 Attach lever handle to top of pump rod, replace stud 807320, lock washer 813899, and nut 813914.
- 2 Attach meter assembly by screwing 819930 nipple into 807703 body and meter. Screw hose assembly into side of meter. Tighten nozzle or tip assembly securely on end of hose.
- 3 Remove nut 806882 from lower part of pump head. Slide drum cover over tube, line up holes for bolts and install same. Replace nut and tighten rigidly.

To Install

- 1 Remove lid or cover from lubricant container.
- 2 Place pump tube into lubricant and center drum cover on container so that it extends over container equally all the way around.
- 3 Engage the three clamp screws 807478 under the top bead of the container and tighten screws equally until cover is clamped firmly onto container.

To Operate

Work lever up and down with slow full strokes. Priming not necessary. Approximately six complete strokes will deliver one pound of lubricant.

Servicing Instructions

Please read all instructions before servicing.

Solutions

Dirt or foreign material may be preventing foot valve from seating properly.

- ▲ First check container to see if lubricant supply is too low. Change drum if necessary.
- ▲ Remove pump from container and unscrew pump tube from unit.
- ▲ Remove piston lock nut 806467 from lower end of rod.
- ▲ Remove valve 807796 and lift of piston 807797. Inspect o-ring packing 806899 for wear, clean thoroughly and replace. Tighten nut rigid.
- ▲ Remove the two screws 806844 from lower end of pump tube and remove ball 806962. Clean ball and tube thoroughly. Replace.
- ▲ Replace tube. (Caution: Do not cross threads as this is a very fine thread.)
- ▲ Tighten rigid to prevent leakage. (Caution: Do not damage tube with pipe wrench.) Unit should now be ready for service.

HAND OPERATED OIL AND ATF PUMPS

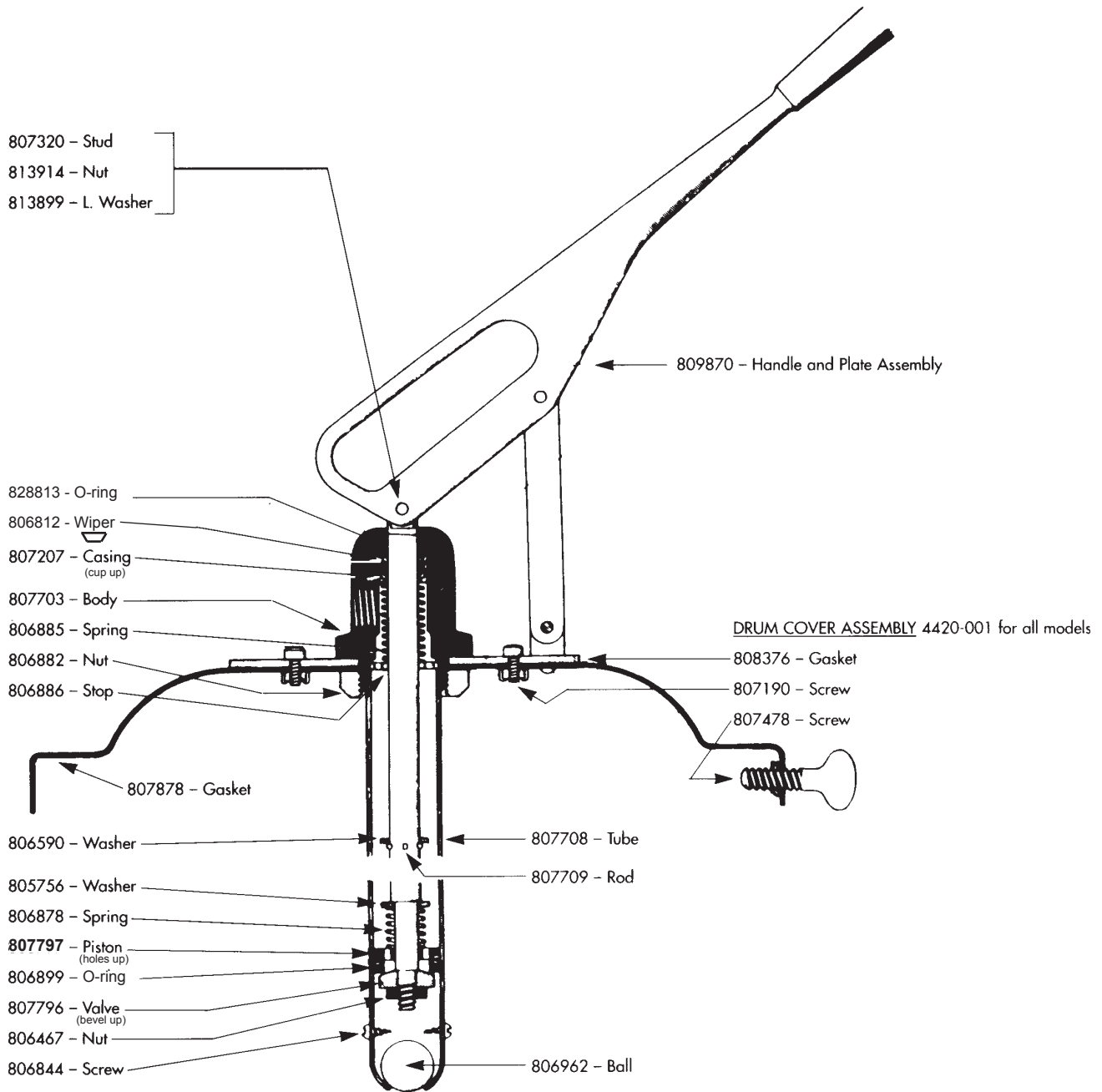

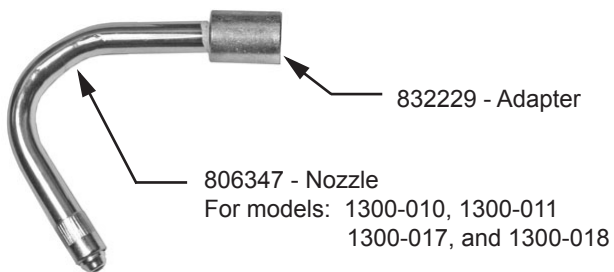
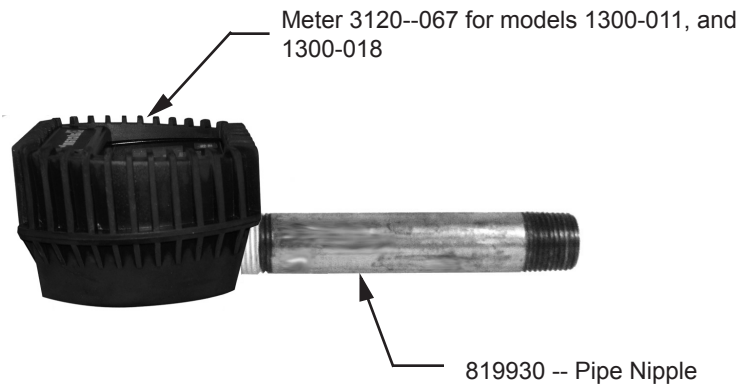

Revision Log:

- Rev. C - changed meter, tip assembly, & hose assembly
- Rev. D - changed adapter & all hose assemblies.
- Rev. E - corrected part number for piston.
- Rev. F - Removed obsolete models & parts, replaced 3120-042 meter with model 3120-067

**For Warranty Information Visit:
www.balcrank.com**

Balcrank® Corporation
115 Reems Creek Road
Weaverville, NC 28787
800-747-5300
800-763-0840 Fax
www.balcrank.com

SERVICE BULLETIN SB 1016
Rev. F 12/10